



Model Number

PGV100-F200A-B17-V1D

Read head for incident light positioning system

Features

- **Mechanically rugged: no wearing parts, long operating life, maintenance-free**
- **PROFINET interface**
- **Noncontact lane tracking of a colored strip**
- **Reading of Data Matrix control codes**
- **Non-contact positioning on Data Matrix code tape**

Diagrams

Coordinates

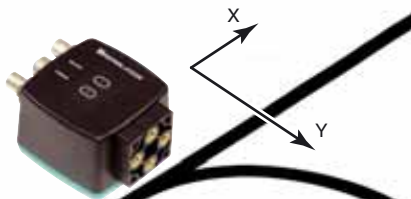

Release date: 2017-03-29 13:45 Date of issue: 2017-09-22 285693-100000_eng.xml

Technical data

General specifications

Passage speed v	≤ 8 m/s
Measuring range	max. 10000 m
Light type	Integrated LED lightning (white/blue)
Read distance	100 mm
Depth of focus	± 20 mm
Reading field	120 mm x 80 mm
Ambient light limit	100000 Lux
Resolution	± 0.2 mm

Nominal ratings

Camera	
Type	CMOS , Global shutter
Processor	
Clock pulse frequency	600 MHz
Speed of computation	4800 MIPS

Functional safety related parameters

MTTF _d	97 a
Mission Time (T _M)	48 a
Diagnostic Coverage (DC)	0 %

Indicators/operating means

LED indicator	7 LEDs (communication, alignment aid, status information)
---------------	---

Electrical specifications

Operating voltage U_B	15 ... 30 V DC , PELV
No-load supply current I_0	max. 400 mA
Power consumption P_0	6 W

Interface

Interface type	100 BASE-TX
Protocol	PROFINET IO Real-Time (RT) Conformance class A
Transfer rate	100 MBit/s

Interface 2

Interface type	USB Service
----------------	-------------

Input

Input type	1 function input 0-level: $-U_B$ or unwired 1-level: $+8$ V ... $+U_B$, programmable
Input impedance	≥ 27 k Ω

Output

Output type	1 to 3 switch outputs , PNP , programmable , short-circuit protected
Switching voltage	Operating voltage
Switching current	150 mA each output

Standard conformity

Emitted interference	EN 61000-6-4:2007+A1:2011
Noise immunity	EN 61000-6-2:2005
Shock resistance	EN 60068-2-27:2009
Vibration resistance	EN 60068-2-6:2008

Ambient conditions

Operating temperature	0 ... 60 °C (32 ... 140 °F) , -20 ... 60 °C (-4 ... 140 °F) (noncondensing; prevent icing on the lens!)
Storage temperature	-20 ... 85 °C (-4 ... 185 °F)
Relative humidity	90 % , noncondensing

Mechanical specifications

Connection type	8-pin, M12x1 connector, standard (supply+IO) 4-pin, M12x1 socket, D-coded (LAN) 4-pin, M12x1 socket, D-coded (LAN)
Housing width	70 mm
Housing height	70 mm
Degree of protection	IP67
Material	
Housing	PC/ABS
Mass	approx. 200 g

Approvals and certificates

UL approval	cULus Listed, General Purpose, Class 2 Power Source, Type 1 enclosure
CCC approval	CCC approval / marking not required for products rated ≤ 36 V

Dimensions

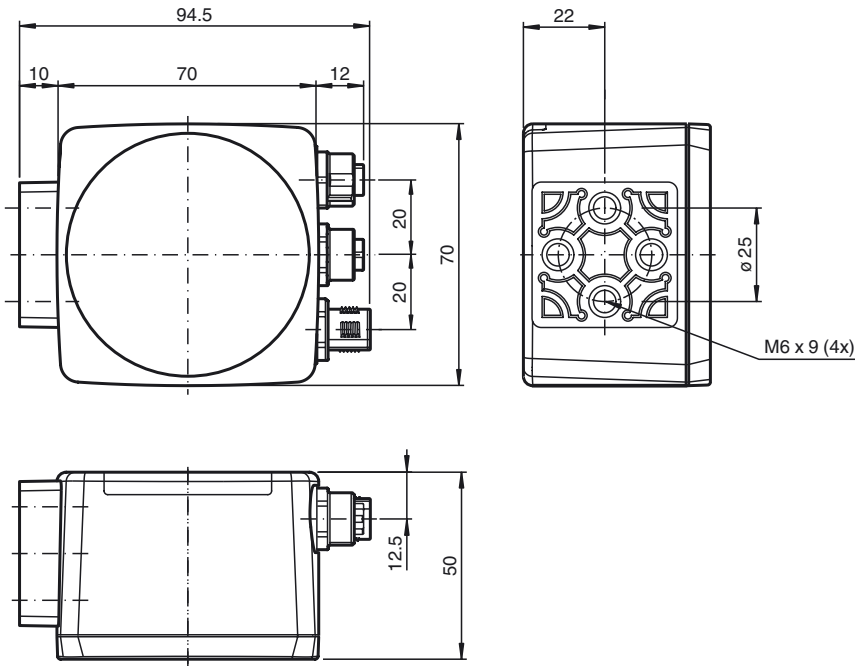

Additional Information

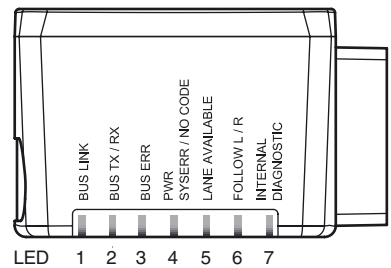
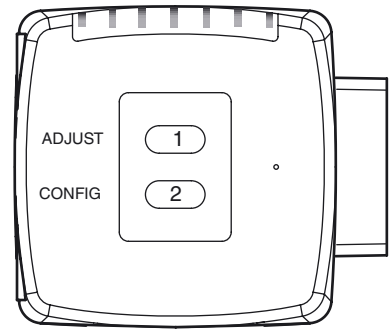

Electrical Connection

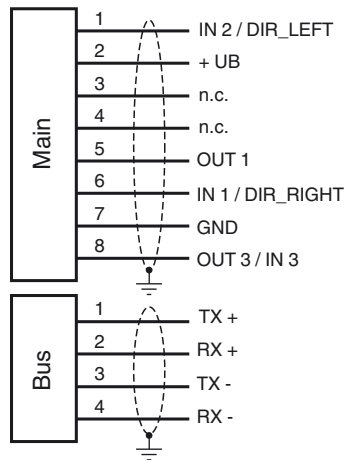

Pinout

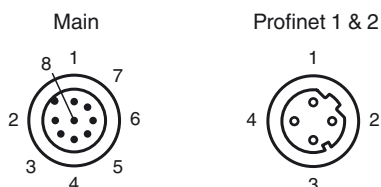

General

The PGV... reader forms part of the positioning system in the Pepperl+Fuchs incident light process. The reader's features include a camera module and an integrated illumination unit. The reader uses these features to detect a colored strip stuck to the floor to track the lane. The reader also detects control codes and position markers in the form of Data Matrix codes attached to a self-adhesive code tape. The code tape is usually mounted in a fixed position instead of the colored strip or parallel to the colored strip. The reader is located on the front of an automated guided vehicle and guides this vehicle along the colored strip.

Accessories

- V1SD-G-2M-PUR-ABG-V1SD-G**
Ethernet bus cable, M12 to M12, PUR cable 4-pin, CAT5e
- V1SD-G-5M-PUR-ABG-V1SD-G**
Ethernet bus cable, M12 to M12, PUR cable 4-pin, CAT5e
- V19-G-ABG-PG9**
Female connector, M12, 8-pin, shielded, field attachable
- V19-G-ABG-PG9-FE**
Female connector, M12, 8-pin, shielded, field attachable
- V19-G-2M-PUR-ABG**
Female cordset, M12, 8-pin, shielded, PUR cable
- V19-G-10M-PUR-ABG**
Female cordset, M12, 8-pin, shielded, PUR cable
- V19-G-5M-PUR-ABG**
Female cordset, M12, 8-pin, shielded, PUR cable
- PCV-SC12**
Grounding clip for PCV system
- PCV-AG100**
Alignment guide for PCV100-* read head
- PCV-LM25**
Marker head for 25 mm code tape
- PCV-MB1**
Mounting bracket for PCV* read head
- PGV33M-CB19-BU**
PGV color-tape blue
- PGV33M-CB19-GN**

Release date: 2017-03-29 13:45 Date of issue: 2017-09-22 285693-100000_eng.xml

Mounting and Commissioning

Mount the reader such that the optical surface of the device captures the optimum reading distance to the colored strip (see "Technical Data"). The stability of the mounting and the manner in which the vehicle is guided ensure that the reader is not operated outside of its depth of focus range. The colored strip must not leave the maximum reading window for the reader during this process. All readers can be adapted to optimally meet specific requirements by means of parameterization.

Indicators and Operating Controls

The PGV... reader is equipped with seven indicator LEDs for carrying out visual function checks and rapid diagnostics. The reader is equipped with two buttons at the back for activating the alignment aid and parameterization mode.

LEDs

LED	Color	Label	Meaning
1	green	BUS LINK	PROFINET communication active
2	yellow	BUS TX / RX	Data transfer
3	red	BUS ERR	PROFINET communication error
4	red / green	PWR / ADJ SYSERR/NO CODE	Code detected/not detected, error
5	yellow	LANE AVAILABLE	Lane available
6	yellow	FOLLOW R/L	"Follow lane" activated
7	red/green/yel- low	INTERNAL DIAGNOSTIC	Internal diagnostics

External Parameterization

In order to parameterize the device externally, the parameterization code is required in the form of a Data Matrix containing the desired reader parameters. Data Matrix code cards detailing the step-by-step process for externally parameterizing the device are printed in the operating instructions for the reader.

The reader can be parameterized only within ten minutes of being switched on. If a key is pressed after ten minutes of the device being switched on, a visual signal is given by the LEDs (LED1, green/LED2, yellow/LED3, red/LED4, green/LED5, yellow/LED6, yellow, flashing for two seconds).

- The switchover from normal mode to parameterization mode is made by pressing button 2 on the back of the reader. To switch the device over, button 2 must be pressed and held for more than two seconds. LED5 then flashes.
Note: Parameterization mode is exited automatically if the device is inactive for one minute. In this case, the reader reverts to normal mode and operates without the settings having been changed.
- Place the parameterization code in the field of vision of the camera module. After the parameterization code is detected, the green LED4 lights up for one second. In the event of an invalid parameterization code, LED4 lights up red for two seconds.
- Briefly pressing button 2 will end parameterization mode.